

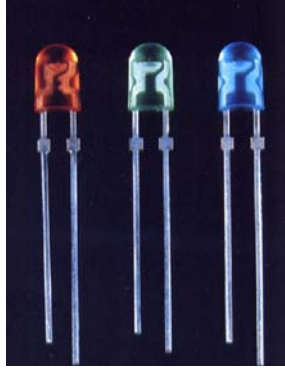

LED

Full Color H35 Oval LED



FEATURES:

- Viewing angle 110° / 45°
- For LED Screen
- UV resistant epoxy

Absolute Max Ratings (Ta=25°C):

Parameter	Symbol	Value	
		Green / Blue	Red
Power Dissipation (mW)	PD	100	125
DC Forward Current (mA)	IF	30	50
Pulsed Forward Current* (mA)	IFP	100	150
Reverse Voltage (V)	VR	5	5
Operating Temperature (°C)	Topr	-30 ~ +80	
Storage Temperature (°C)	Tstg	-40 ~ +100	

* Duty 1/10 Pulse Width 0.1ms

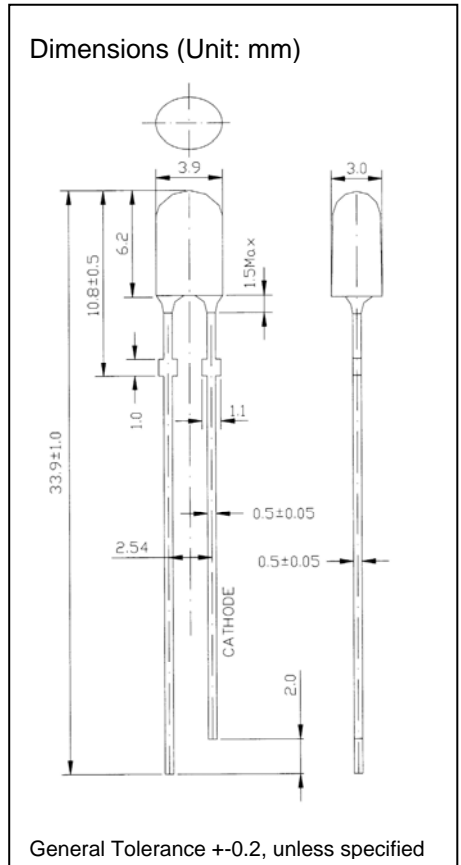

Electrical Optical Characteristics (Ta=25°C):

Part Number	Luminous Intensity (mcd)			Forward Voltage (V)			Dominant Wavelength (nm)			Reverse Current (μA)	
	Min	Max	IF(mA)	Type	Max	IF(mA)	Min	Max	IF(mA)	Max	VR(V)
H35URDP-S2	400	720	20	2.0	2.2	20	620	625	20	5	5
							625	630			
H35FDP-S1	970	1750	20	3.2	3.6	20	520	525	20	10	5
							525	530			
H35BDP-S1	350	620	20	3.2	3.6	20	465	470	20	10	5
							470	475			

Luminous Intensity Rank (mcd)

Red		Green		Blue	
Rank	Data	Rank	Data	Rank	Data
F	400-535	J	970-1300	E1	350-460
F1	460-620	J1	1120-1500	F	400-535
G	535-720	K	1300-1750	F1	460-620

Directive Characteristics

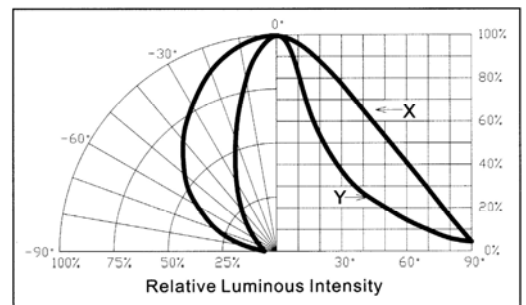

Package:

Bulk: 500 pcs/bag
Taping: 3,000 pcs/reel

Precaution in handling:

1. It is advised to keep 4.5mm minimum clearance between the resin and the soldering point when soldering.
2. The user is required to handle with care for the Blue and Green LED's which are sensitive to ESD.