

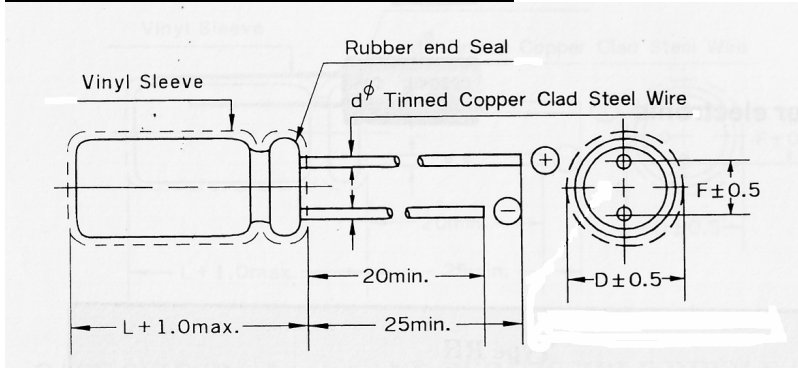

ALUMINUM ELECTROLYTIC CAPACITOR

TYPE RH

HIGH VOLTAGE, RADIAL LEADS



Dimension in mm

D	6.3	8	10	13	16	18
F	2.5	3.5	5.0	7.5	7.5	7.5
D	0.5	0.5	0.6	0.6	0.8	0.8

CASE SIZE (DxL mm) AND PERMISSIBLE RIPPLE CURRENT (mA rms, at 85 120 Hz):

W.V.	160V		200V		250V		350V		400V		450V	
	μF	DxL	R.C.	DxL	R.C.	DxL	R.C.	DxL	R.C.	DxL	R.C.	DxL
0.47	6.3x11	7	6.3x11	9	6.3x11	11	8x11	13	8x11	15	8x11	17
1.0	6.3x11	9	6.3x11	12	6.3x11	14	8x11	17	8x11	18	8x11	19
2.2	6.3x11	17	6.3x11	19	6.3x11	21	8x11	24	10x12	27	10x12	29
3.3	6.3x11	22	6.3x11	27	8x11	31	10x12	34	10x12	37	10x16	40
4.7	6.3x11	32	8x11	35	8x11	39	10x12	42	10x16	45	10x18	47
10	8x11	57	10x12	62	10x16	67	10x21	70	13x21	74	13x21	77
22	10x16	112	10x21	115	13x21	120	13x21	122	13x26	127	16x26	130
33	10x21	140	13x21	151	13x21	156	13x26	160	16x26	165	16x32	170
47	13x21	182	13x21	190	13x26	201	16x26	210	16x32	220	18x36	300
100	13x26	305	16x26	325	16x32	345	18x36	360				
220	16x36	515	18x42	545								
330	18x42	560										